

# CALIX

 **DIGITAL LASER SENSORS**

for thickness measuring ranges from 5 mm to 30 mm

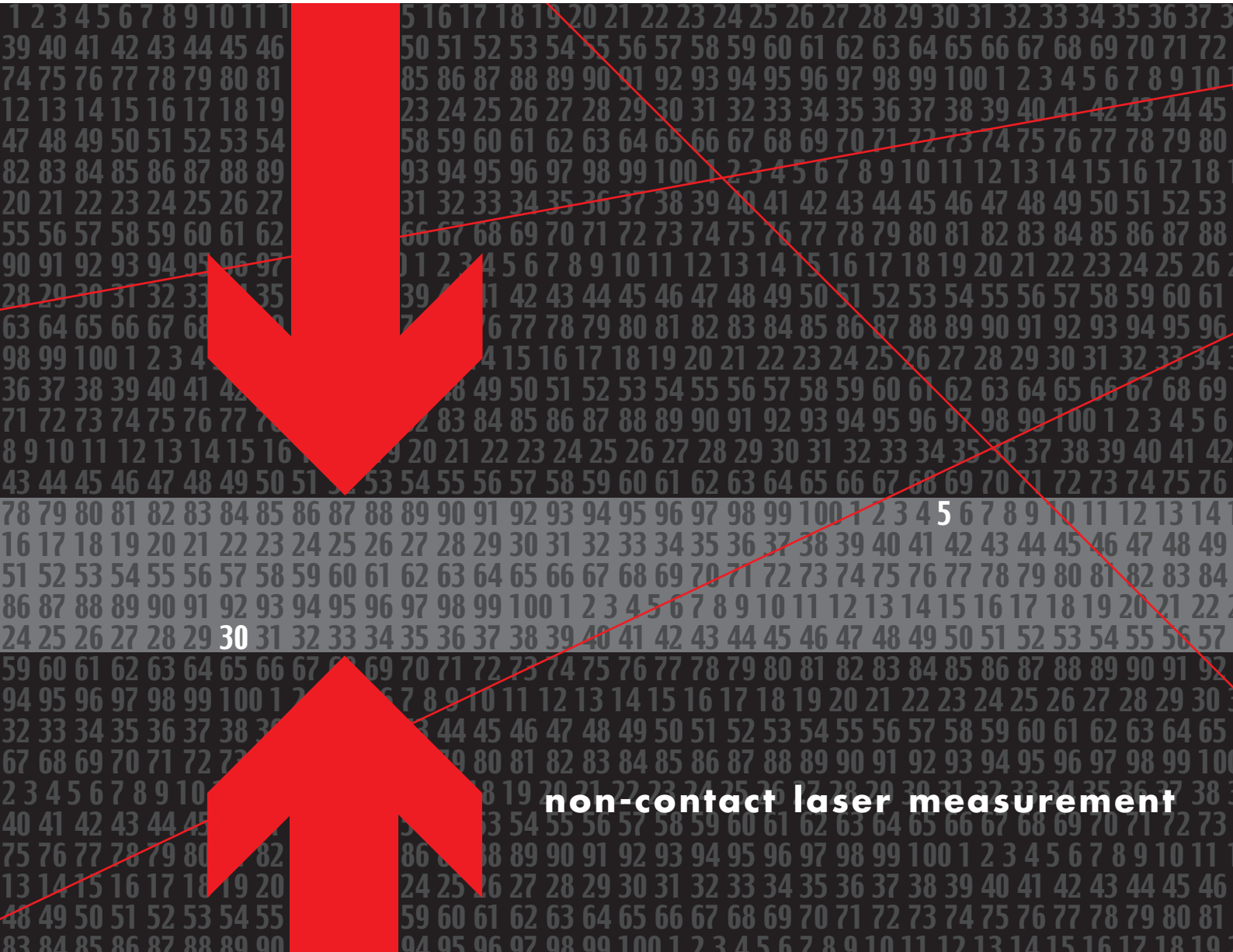

**non-contact laser measurement**





# CALIX LASER TRIANGULATIONS THICKNESS SENSORS.



## HIGHLIGHTS.

- Thickness measurement with **one single** sensor
- Highest precision
- Temperature stabilized
- 4 kHz measuring frequency
- Ethernet output on-board

## INTEGRATED, TEMPERATURE STABILIZED, PROFITABLE.

CALIX series is the first LAP product family for thickness measurement in **one single** sensor housing. They can be used instead of applications consisting of displacement sensors and measuring frame without the need for temperature control and frequent recalibration.

The alignment of measuring beams is optimised during production at LAP. CALIX sensors don't need complicated adjustments of opposing sensors in the measurement frame. Errors related to alignment won't occur.

LAP CALIX sensors can easily be integrated into production lines. They reach over the objects to be measured from the side, without the need for O-frames or bridges.

## FLEXIBLE, PRECISE, VERSATILE.

CALIX sensors are available with different measuring ranges and limb lengths. The limb length limits the distance of the measuring spot from the objects edge. CALIX sensors may also be used for traversing applications, moving in and out or along the edge of the object.

Sensors of CALIX series provide extremely precise results on virtually all materials, independent of limb length and measuring range. They automatically adapt to changing colors and surfaces. Even measurements on shiny aluminium, non-vulcanized black rubber, and soft or sticky materials are possible.

---

# SOLUTIONS FOR YOUR COMPANY.

## THE OPERATING PRINCIPLE.

CALIX sensors operate by differential triangulation, similar to mechanical micrometers.

Two triangulation modules measure the distance to the objects surface from opposing directions. The zero point is determined during production.

Thickness is calculated by subtraction of the measured values from the known distance to the zero point.

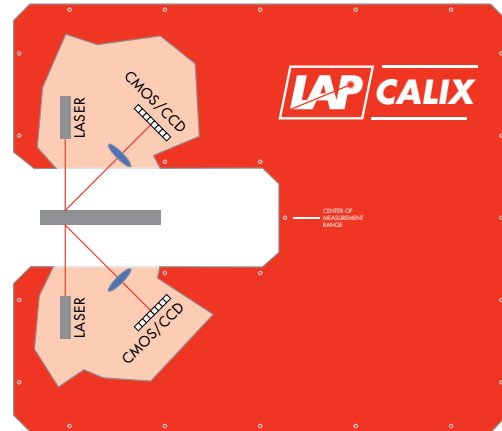

## THE COMPLETE SOLUTION.

Measurement results of CALIX sensors can be directly displayed or transmitted to PCs or PLCs for further use.

For two-track thickness measurement, two sensors are placed on opposite sides of the measuring object. This application may detect cross variation of thickness.

Grouping sensors in transport direction offers the possibility for multi-track measurements.

Depending on the width, sensors with longer limbs may even measure in the middle of the object.

To get profile data, CALIX sensors may be moved in and out or along the objects edge.

As upper and lower triangulation modules don't change their relative positions, CALIX can reach higher precision than applications with sensors that move separately.

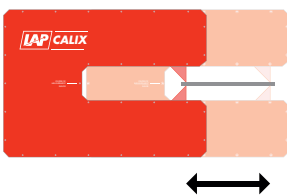
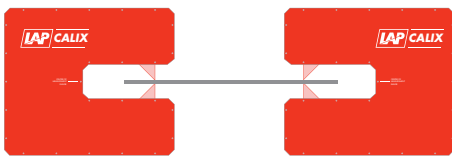

# SIMPLE INTEGRATION IN YOUR PROCESSES.

## EASY INTEGRATION.

LAP CALIX sensors offer Ethernet and RS485 outputs.

Ethernet UDP connects single CALIX sensors to network cards of PCs or PLCs. A simple software for receiving measurement data from the computers Ethernet port is included.

The RS485 signal is compatible to all equipment that uses LAP SynchroNet protocol.

RS485 can transfer the data of several CALIX sensors simultaneously. Interfaces offer connection to Profibus DP or RS232 (ASCII).

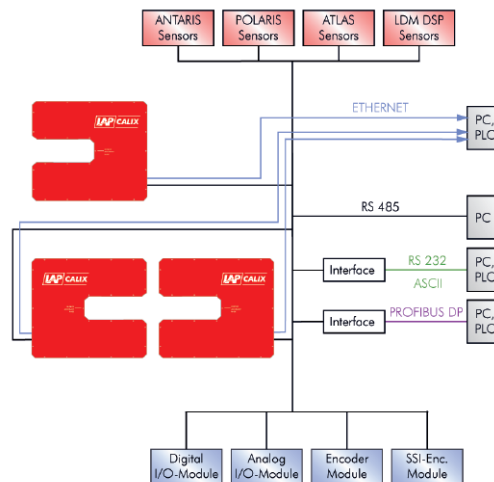

The integrated signal processing and the wide range of interfaces lets you easily handle applications from individual sensors to complex multi-sensor measuring systems.

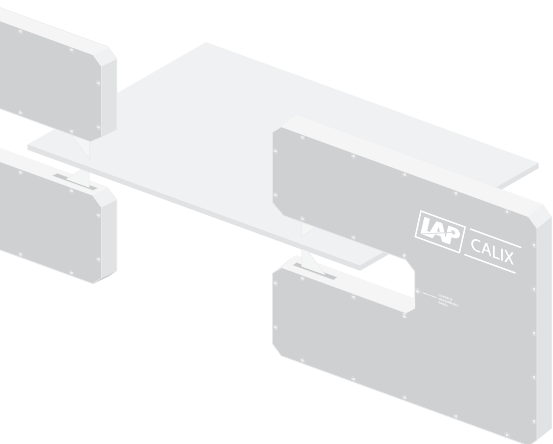

## DIGITAL PRECISION.

In contrast to conventional laser sensors, CALIX sensors use high resolution CCD or CMOS line scan cameras, a DSP to provide pure digital acquisition of measured values and digital outputs. This combination provides for a very stable output signal and guarantees precise transmission in noisy industrial environments, even over long distances.

## DATA ACQUISITION AND SOFTWARE.

LAP offers software for data collection, visualization and documentation. For archiving, it can be provided with a database or it can be linked to existing customer databases. Software versions are available for thickness measuring with single-track or multi-track applications and for profile or flatness measurement with traversing sensors.



**L A S E R**

Sensors, Line Lasers, Projectors  
Systems & Solutions

# TECHNICAL DATA.

## GENERAL DATA.

Laser type, wavelength	Diode, 670 nm, red
Laser class	2
Measuring frequency	up to 4 kHz
Outputs	Ethernet UDP, RS485
Power supply	24 V DC
Enclosure rating	IP 54
Ambient conditions	0 - 40°C / 35 - 85% rel. humidity, non-condensing

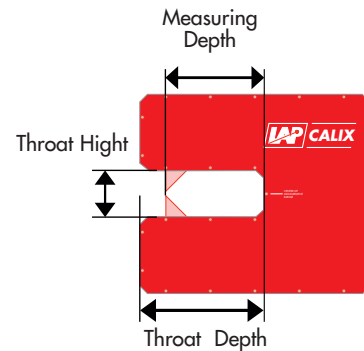

## MODELS.

Besides standard models, LAP offers customized versions.

Modell	Measuring Range mm	Measuring Depth mm	Repeatability µm	Linearity µm	Dimensions L x H x W, mm	Throat Depth mm	Throat Height mm	Weight kg
CALIX S 5	5	ca. 250	± 3,5	± 5	530x463x56	275	80	ca. 13
CALIX S 10	10	ca. 250	± 6,5	± 10	530x463x56	275	80	ca. 13
CALIX S 30	30	ca. 250	± 20	± 30	530x463x56	275	80	ca. 13

Modell	Measuring Range mm	Measuring Depth mm	Repeatability µm	Linearity µm	Dimensions L x H x W, mm	Throat Depth mm	Throat Height mm	Weight kg
CALIX L 5	5	ca. 800	± 3,5	± 5	1080x463x80	825	80	ca. 35
CALIX L 10	10	ca. 800	± 6,5	± 10	1080x463x80	825	80	ca. 35
CALIX L 30	30	ca. 800	± 20	± 30	1080x463x80	825	80	ca. 35

Subject to modifications

## ACCESSORIES AND OPTIONS.

- Several measuring tracks in one housing
- Individual limb lengths
- Air purging housings to keep sensors clean, displays
- Individual software

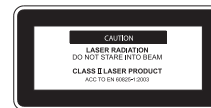

LAP has a great deal of experience with customer-specific turn-key solutions for individual measuring applications in a multitude of different industries. Please inquire!



**L A S E R**

Sensors, Line Lasers, Projectors  
Systems & Solutions

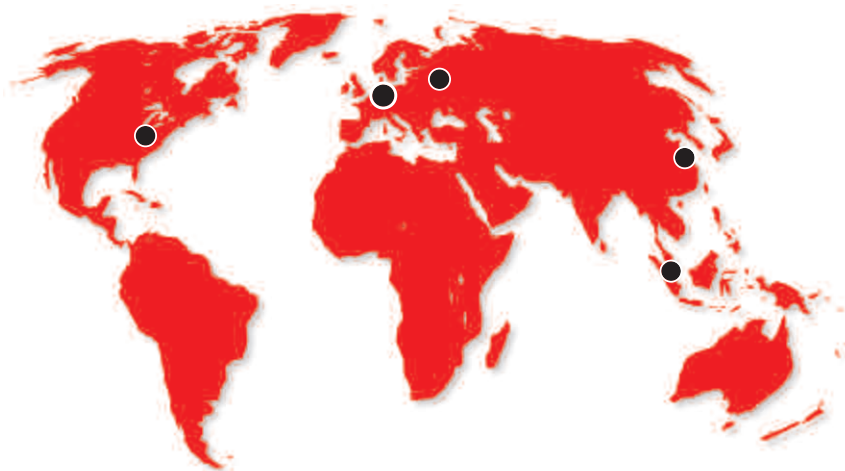

---

**LAP Laser LLC.**

Sales, Service

7669 Wooster Pike  
Cincinnati, OH 45227  
USA

Phone +1 (513) 271-4529  
Fax +1 (513) 271-3821  
Email [info-us@lap-laser.com](mailto:info-us@lap-laser.com)

---

**LAP GmbH  
Laser Applikationen**

Headquarter: Production, Sales, Service

Zeppelinstr. 23  
21337 Lueneburg  
Germany

Phone +49 (0)4131 9511-95  
Fax +49 (0)4131 9511-96  
Email [info@lap-laser.com](mailto:info@lap-laser.com)

---

**LAP Laser Applications  
Asia Pacific Pte Ltd**

Sales, Service

Block 750A, #07-02 Suite 8  
Technopark at Chai Chee  
Singapore 469001  
Singapore

Phone +65 6536 9990  
Fax +65 6533 6697  
Email [info-asia@lap-laser.com](mailto:info-asia@lap-laser.com)

---

**LAP GmbH  
Laser Applikationen  
Moscow Representative Office**

Sales

1. Kasatschi Pereulok No. 7  
119017 Moscow  
Russian Federation

Phone +7 495 7304043  
Fax +7 495 7304044  
Email [info-russia@lap-laser.com](mailto:info-russia@lap-laser.com)

---

**LAP Laser Applications  
Asia Pacific Pte Ltd  
Shanghai Representative Office**

Sales, Service

31/F Haitong Securities Tower  
689 Guang Dong Road  
Shanghai 200001  
China

Phone +86 (21) 5047-8881  
Fax +86 (21) 5047-8887  
Email [info-asia@lap-laser.com](mailto:info-asia@lap-laser.com)

---

 Partners

[www.LAP-LASER.com](http://www.LAP-LASER.com)



**L A S E R**

Sensors, Line Lasers, Projectors  
Systems & Solutions